

Report Number: 14110934

Nanjing Guhua MetalWork Co Ltd
Xiongzhou Industrial Park
Luhe District
Nanjing
ChinaOrder Number : GH1120
Date of Issue: 19/12/2014
Test Date : 18/12/2014
to 18/12/2014

This report details the results of tests carried out on Pressed Swivel Coupler Zinc Plated used for connecting steel tubes of 48.3mm outside diameter and of at least 3.2mm nominal wall thickness at a minimum in the construction of working scaffolds and falsework required for the construction, maintenance, repair and demolition of buildings and structures.

Description and Marks on couplings

Pressed Swivel Coupler Zinc Plated

Marks : CLASS A L EN74-1 GH 0914

Basis of Tests

The couplings have been tested in accordance with the relevant sections and requirements of EN 74-1 :2005.

Information supplied by the customer

Manufactured by: Nanjing Guhua MetalWork Co Ltd
Shape: As per drawings shown at the end of this report
Dimensions: As per drawings shown at the end of this report
Mass: As per drawings shown at the end of this report
Material Characteristics: As per drawings shown at the end of this report

RESULTS

Design

The design of the coupling complied with the requirements of the relevant items in clause 6.2 of the standard.

Dimensions and Material Characteristics

The measured dimensions, mass and material characteristics, of the couplings, were all within the tolerances as specified by the manufacturer. (Drawings are shown at the end of this report)

Marking

The markings satisfy the requirements laid out in EN74-1.

Results of all tests performed are detailed on the following pages.

All requirements stated are minimum values.

This report consists of the report, appendix A and appendix B.

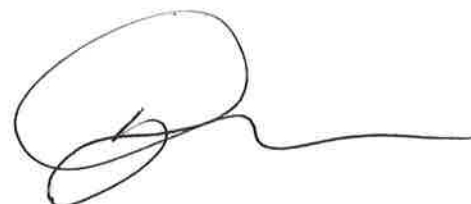
Authorised Signatory
L Mangham
Operations Manager

Report Number: 14110934

Slipping Force Tests, tested in accordance with Clause 7.2.1

Tested using 3.2mm steel tube (RT_{S1})		
Test Number	$\Delta_1 \leq 7\text{mm}$ (kN)	$1 \leq \Delta_2 \leq 2\text{mm}$ (kN)
1	14.18	20
2	13.98	20
3	14.24	20
4	14.64	20
5	15.24	20
6	13.98	20
7	14.83	20
8	16.01	20
9	12.98	20
10	14.32	20

$F_{S5\%}$	12.81	20.00
------------	--------------	--------------

Tested using 4.0mm aluminium tube (RT_A)		
Test Number	$\Delta_1 \leq 7\text{mm}$	$1 \leq \Delta_2 \leq 2\text{mm}$
11	14.49	20
12	14.84	20
13	15.02	20
14	12.98	20
15	13.24	20

$F_{S5\%}$	11.94	20.00
------------	--------------	--------------

Photograph of Setup for Slipping Force



The photograph above shows the setup for slipping force but is not necessarily the coupler under test.

The $F_{S5\%}$ figures must be equal to or greater than the requirements stated below.

Requirements from EN 74-1 table 8:

Class B:	$\Delta_1 \leq 7\text{mm} = 10\text{kN}$ Minimum
	$1 \leq \Delta_2 \leq 2\text{mm} = 15\text{kN}$ Minimum
Class A:	$\Delta_1 \leq 7\text{mm} = 7\text{kN}$ Minimum
	$1 \leq \Delta_2 \leq 2\text{mm} = 10\text{kN}$ Minimum

From the results, the prototype is Accepted to Class A for slipping force

Load-displacement curves are shown in Appendix A as charts 1 to 15

Low

Report Number: 14110934

Failure Force, tested in accordance with clause 7.2.2

Tested using solid steel bar (RB)	
Test Number	Maximum Load $P_{f,ult}$ (kN)
16	45.62
17	40.84
18	41.04
19	44.34
20	41.21
$F_{f,5\%}$	30.01

The $F_{f,5\%}$ figures must be equal to or greater than the requirements stated below.

Requirements from EN 74-1 table 8:-
 $P_{f,ult}$ = 20.0kN minimum Right Angle couplers &
 14.0kN for Swivel couplers

Load-displacement curves are shown in Appendix B as charts 16 to 20

From the results, the prototype is Accepted to Class A for failure force

Photograph of setup for Failure Force



The photograph above shows the setup for failure force but is not necessarily the coupler under test.

Indentation Check, tested in accordance with clause 7.5

Tested using 2.7mm wall steel tube (RT _{S2})	
Test Number	Maximum Indentation Δ_{10} (mm)
26	0.58
27	0.54
28	0.39
29	0.81
30	0.63

The figures must be equal to or greater than the requirements stated below.

Requirements from EN 74-1 table 8:-
 P_{ind} = ≤ 1.5 mm

From the results, the prototype is Accepted to Class A for indentation check

Photograph of setup for Indentation Check



The photograph above shows the setup for indentation check but is not necessarily the coupler under test.

Lm

Report Number: 14110934

Drawings

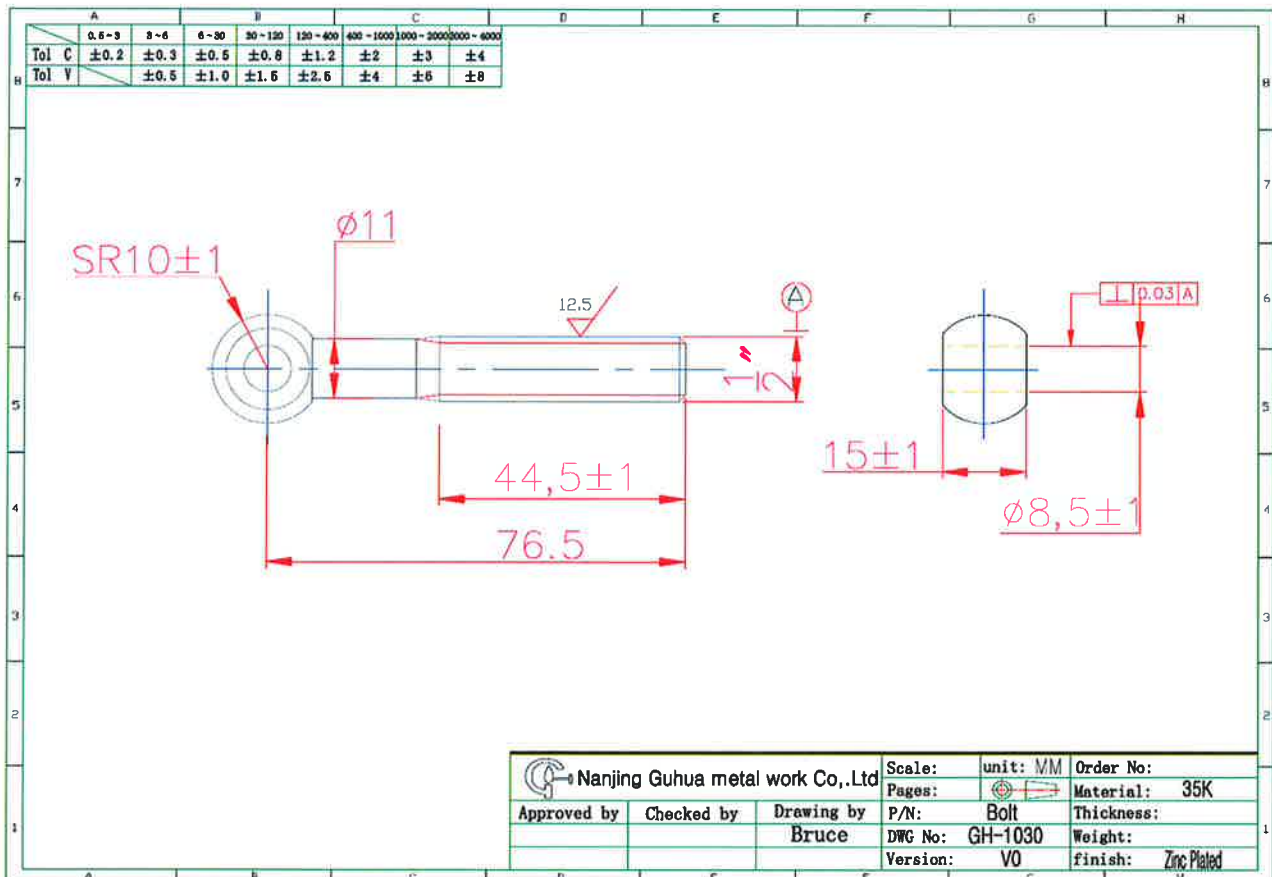
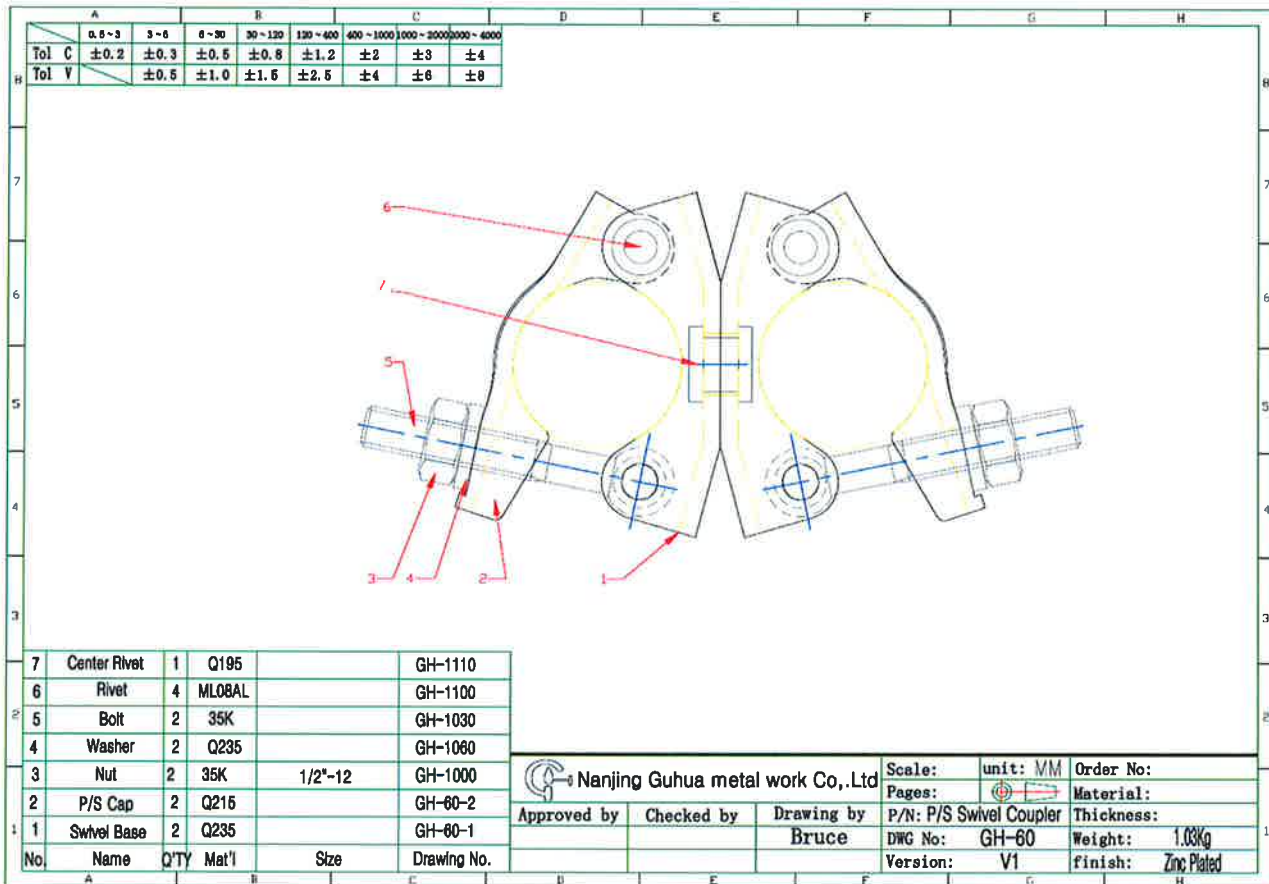

Low



Report Number: 14110934

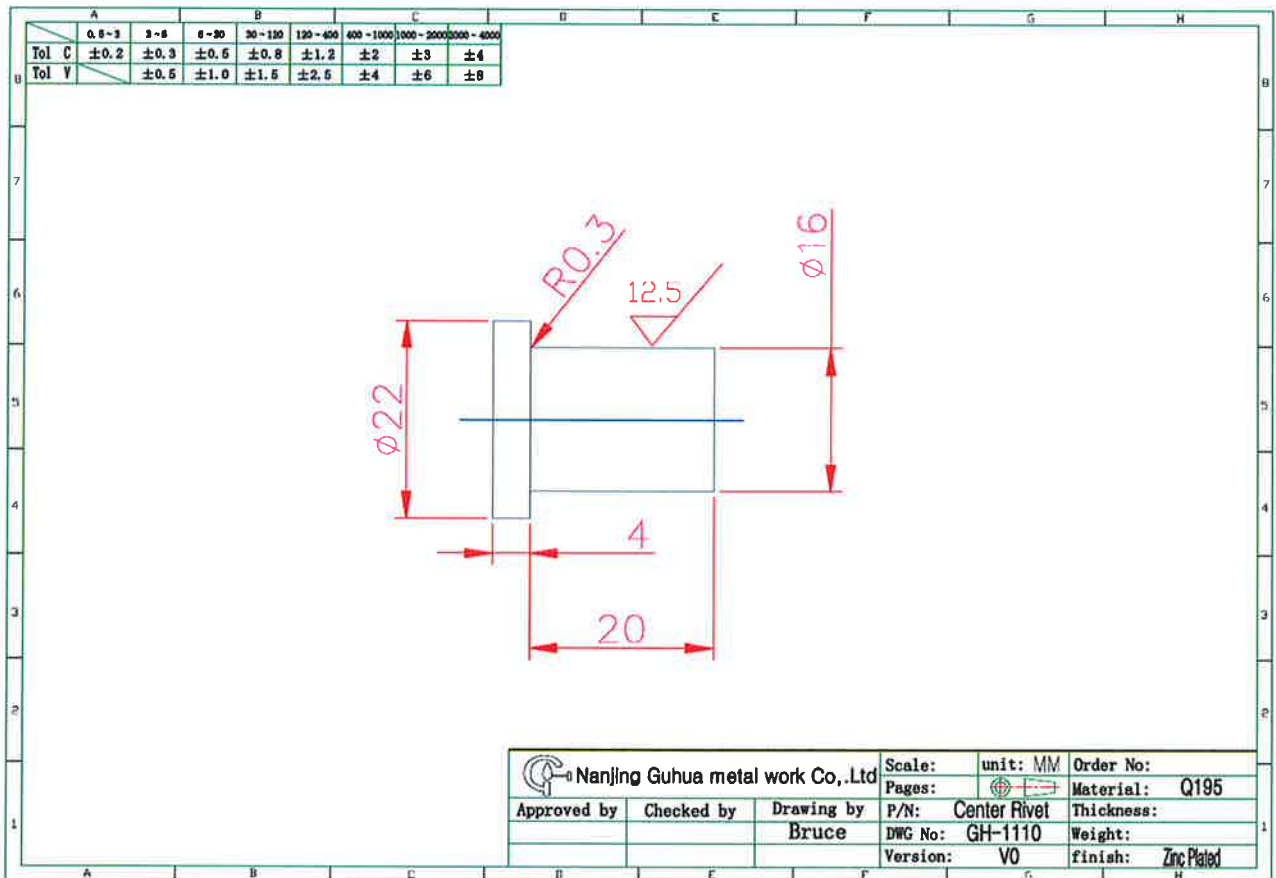
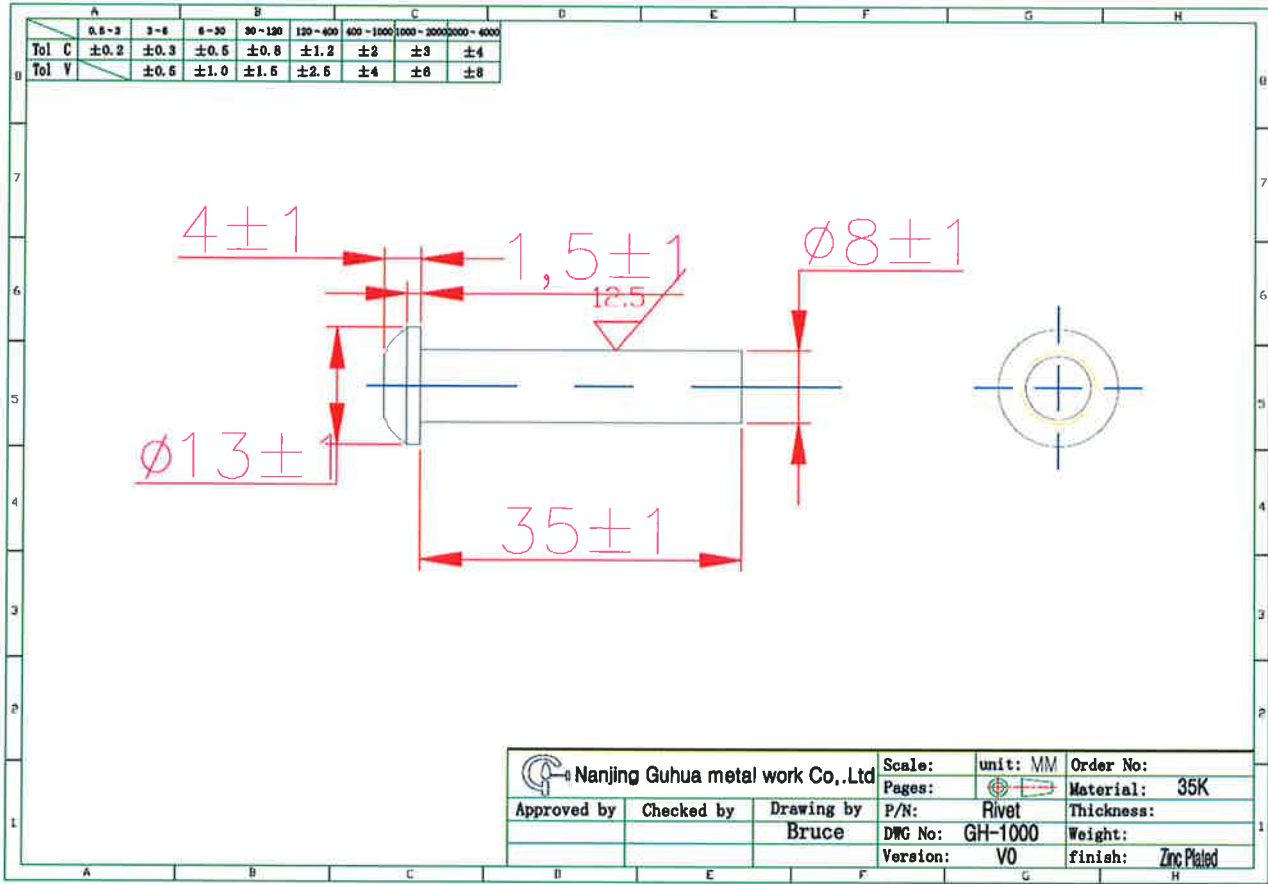

Ln



Report Number: 14110934

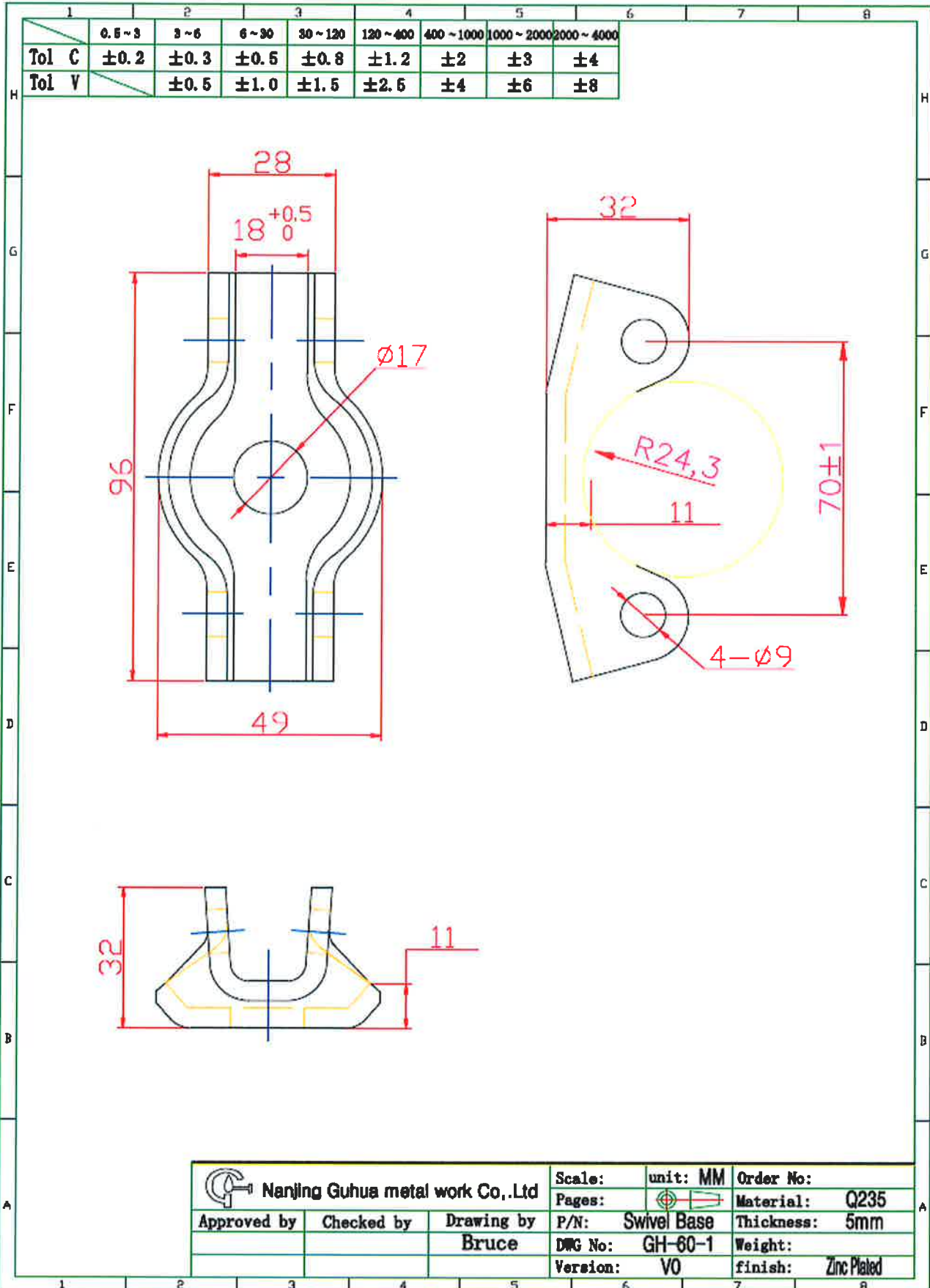

Low



Report Number: 14110934

Photograph of coupler under test



End of Report

Lm

Test Report 14110934



Appendix A

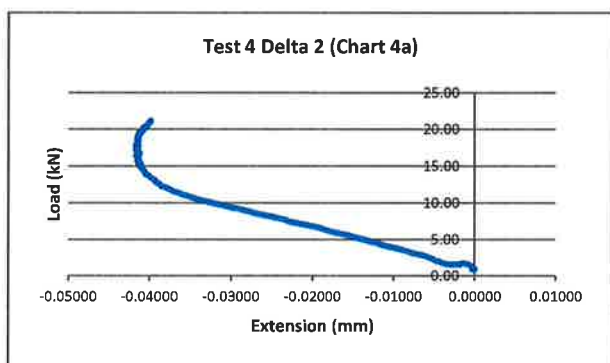
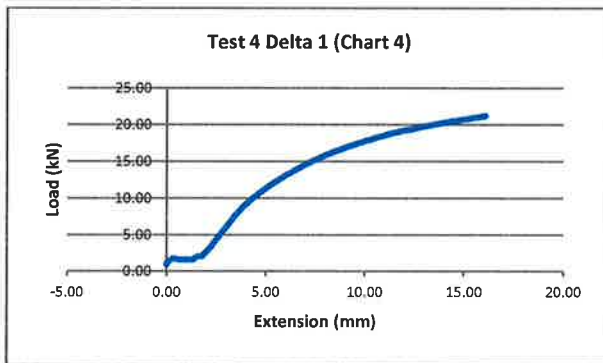
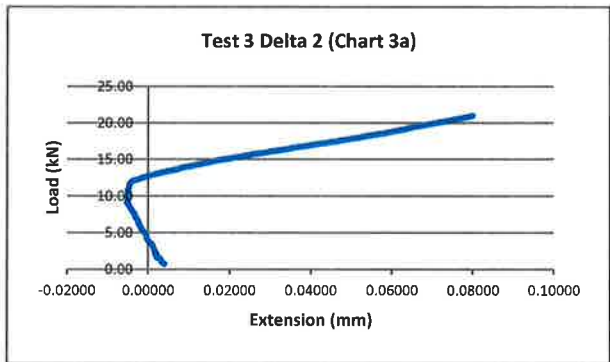
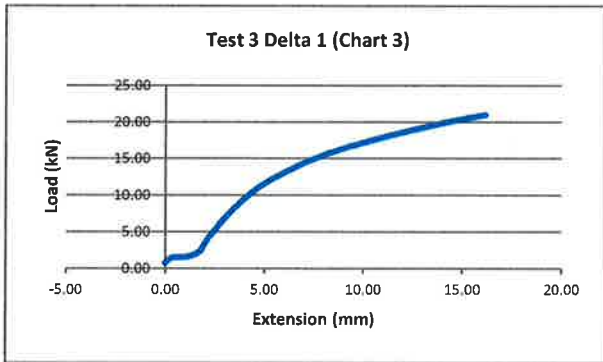
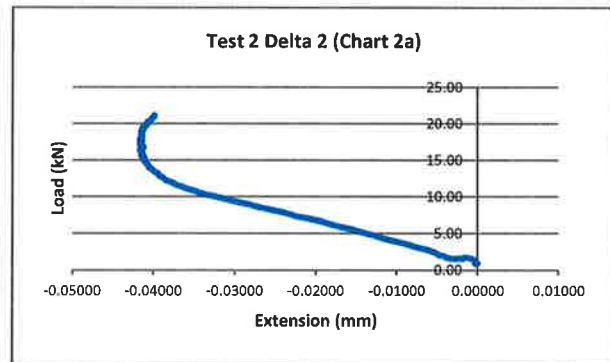
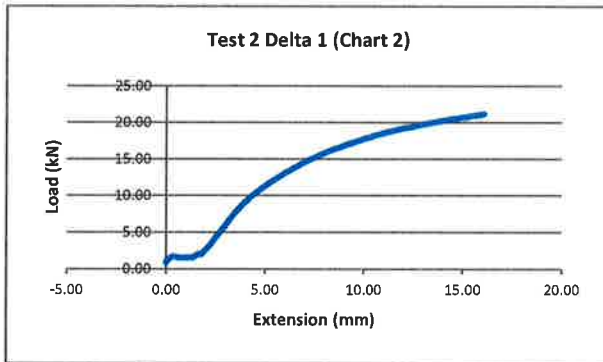
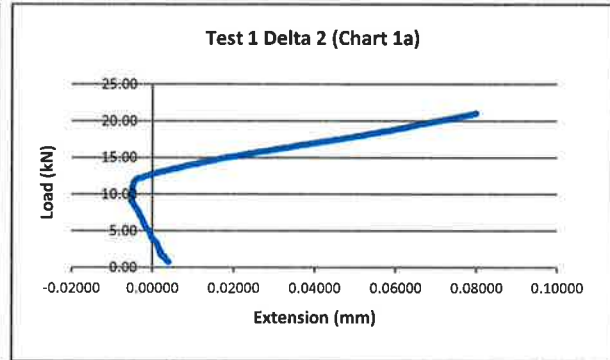
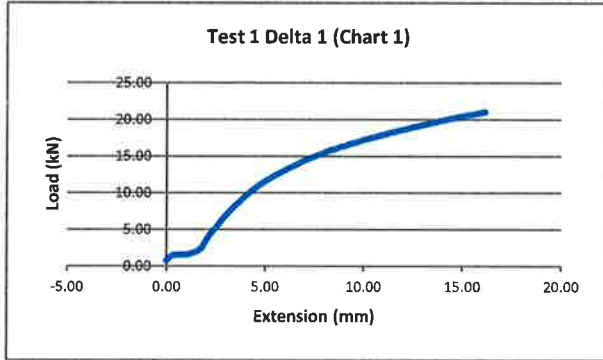

Low

Test Report 14110934

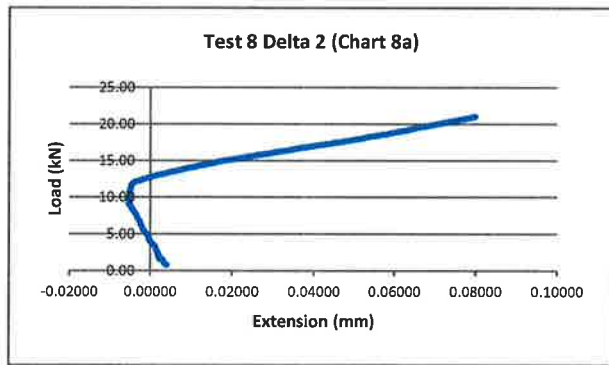
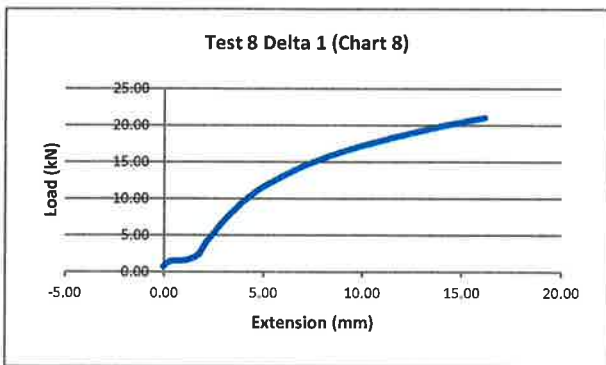
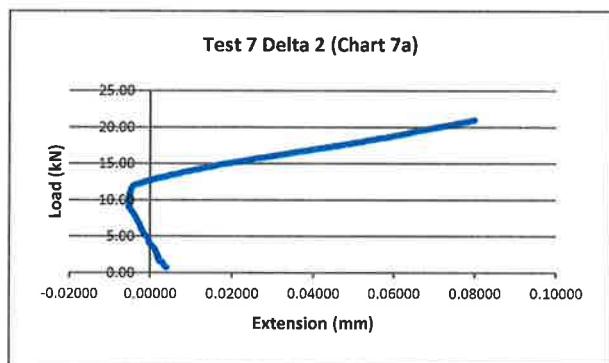
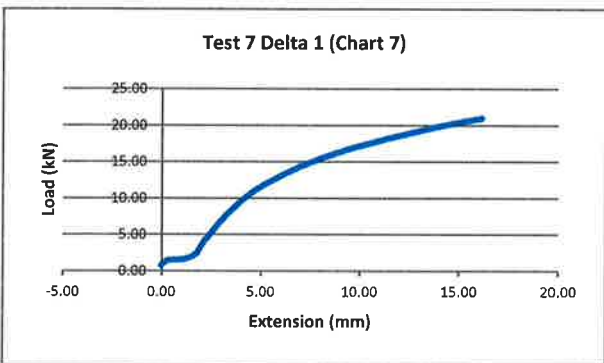
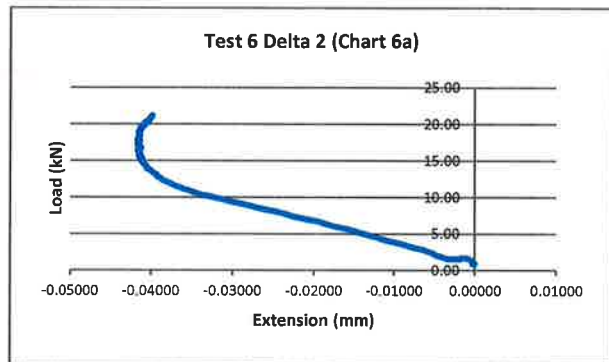
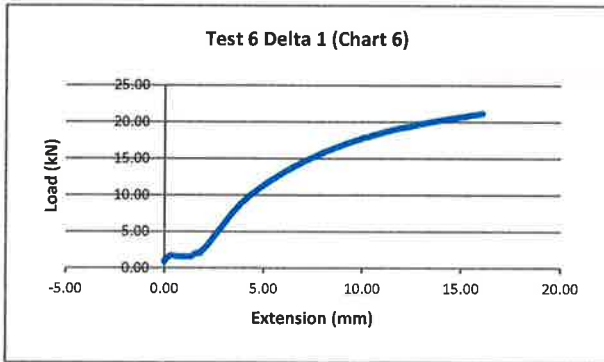
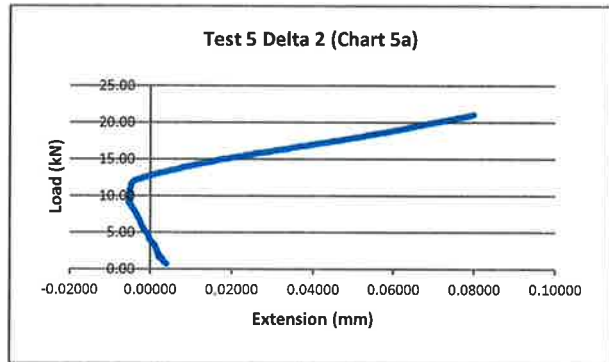
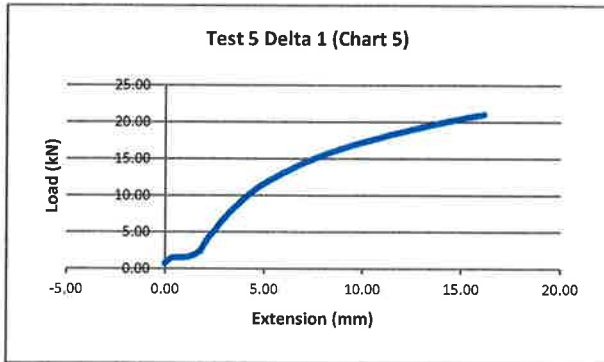

Lu

Test Report 14110934

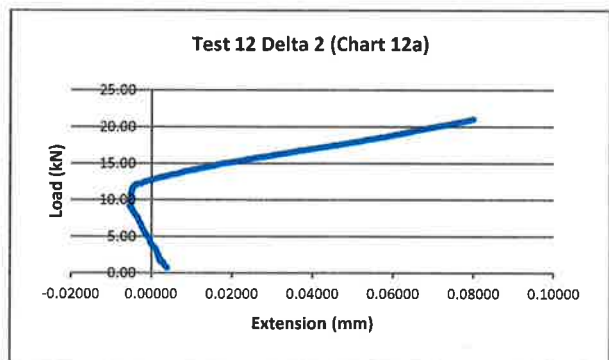
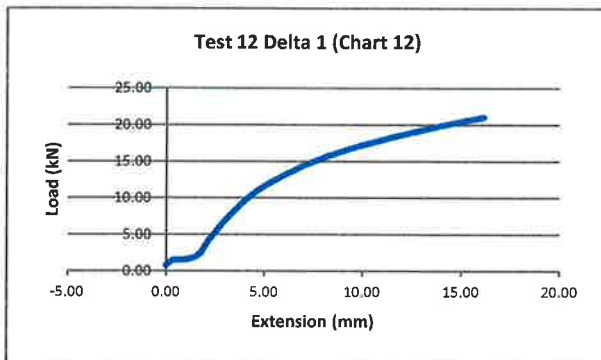
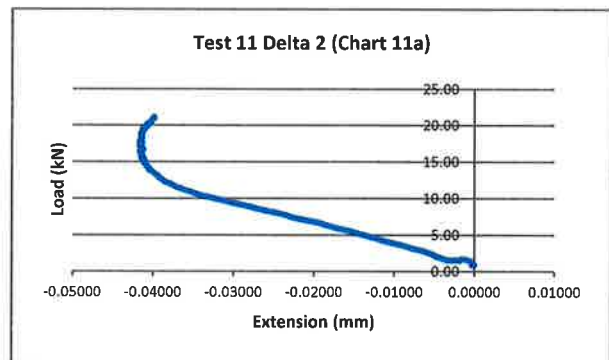
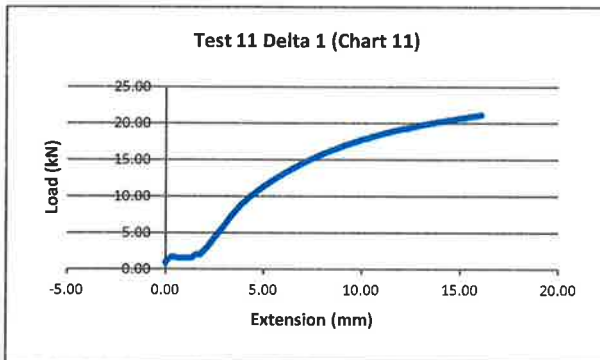
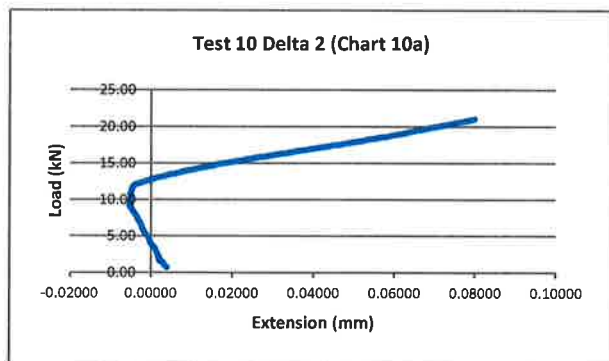
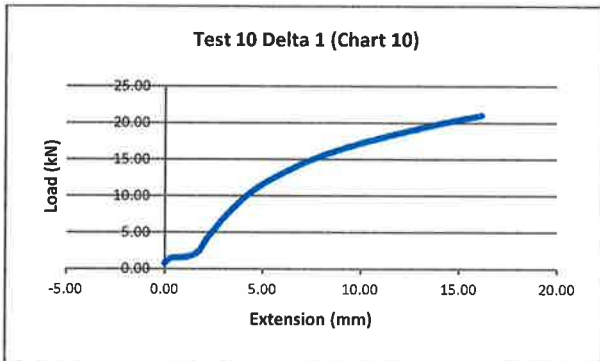
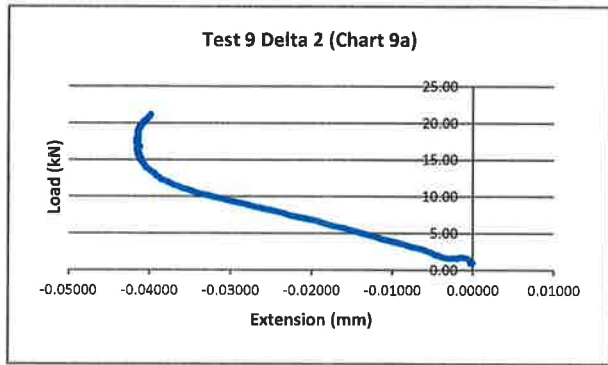
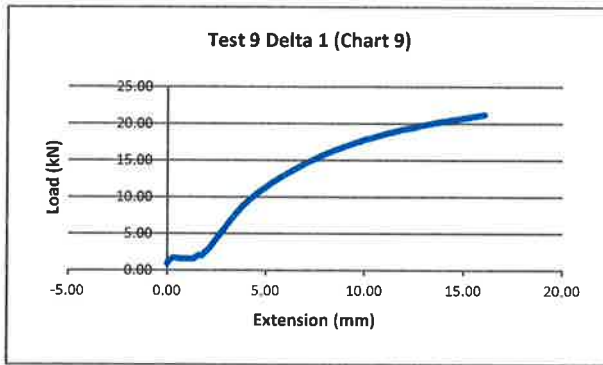

Lu

Test Report 14110934

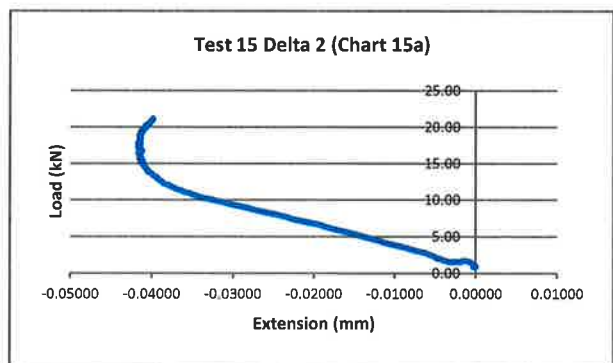
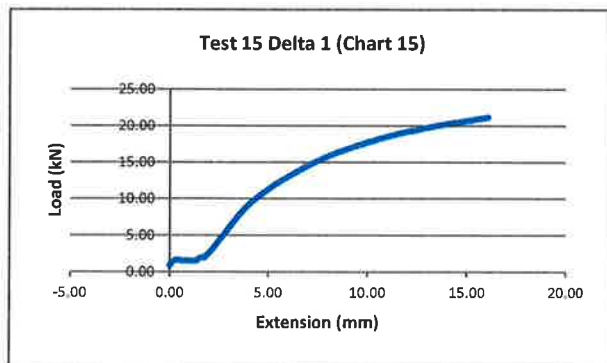
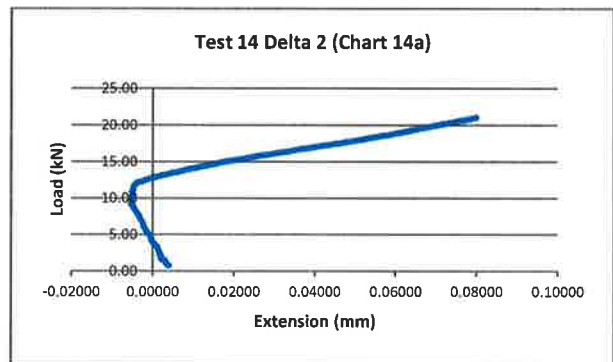
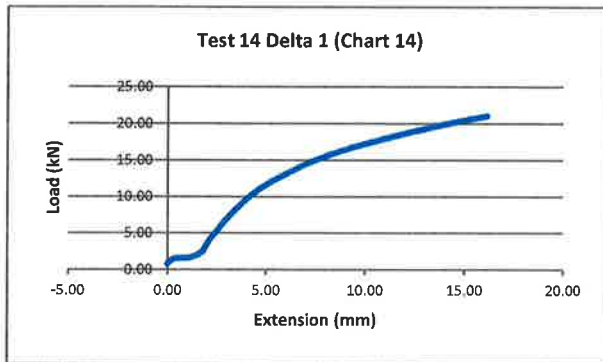
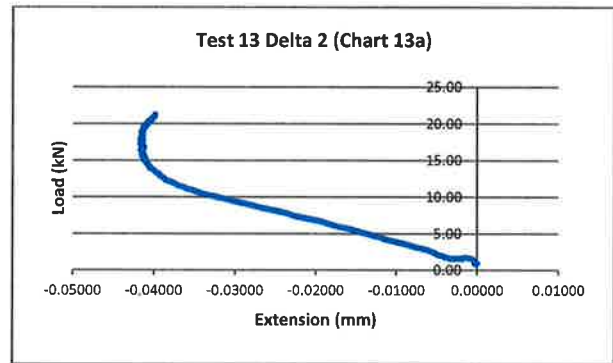
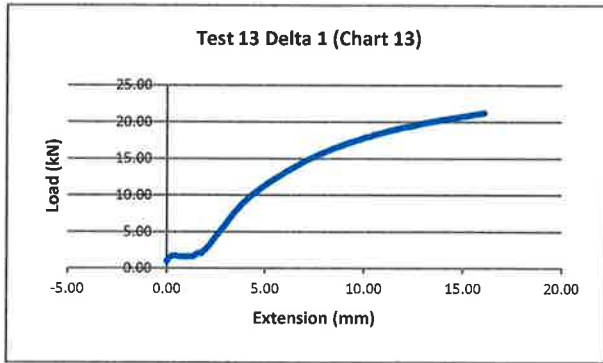

Low

Test Report 14110934



Appendix B

